



“The Nativity Story”

A Shadow Puppet Play



Shadow puppetry was a form of entertainment popular during the 18th century in both Europe and America, however this form of puppetry dates back even further throughout the Orient.

THE STAGE:

The first thing you will need to do is create a stage. There are several ways this can be done, from complex wooden frames to simple cardboard boxes like the one we will be making.

- Supplies:
- a large cardboard box
 - ruler
 - pencil
 - sheet of muslin as large as the bottom of the box
 - utility knife
 - a lamp
 - duct tape

On the bottom side of the box, measure in 2 or 3 inches from the outer edge, drawing a rectangle. Have a parent cut out the rectangle, leaving a frame around the edge.

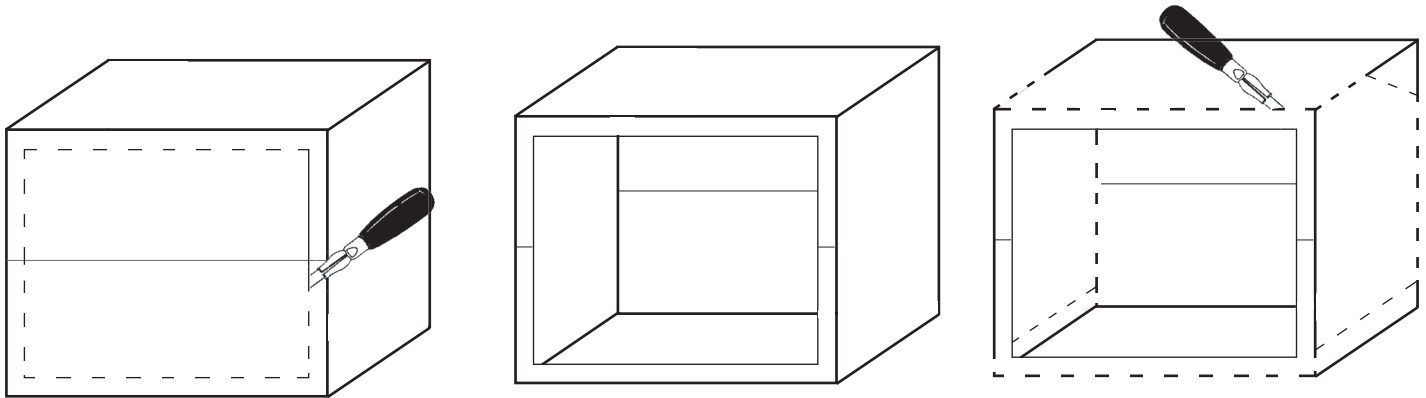

Continue cutting out where dashed lines are indicated, so that the final results look like the sample below, with a center rectangle and two wings on the side. Place the piece of muslin so that it fully covers the rectangle hole, making sure to tape it down tight and wrinkle-free.

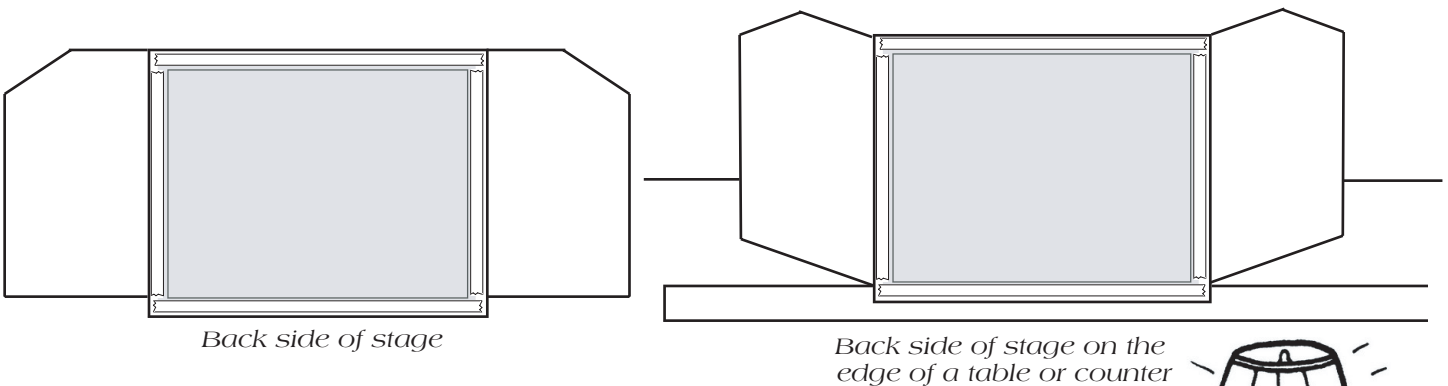

Place on the edge of a table and have a lamp perched on a nearby table or chair to cast strong light on the muslin from behind. You may wish to remove the shade to spread the light.

Your stage is now ready! Now on to the puppets!

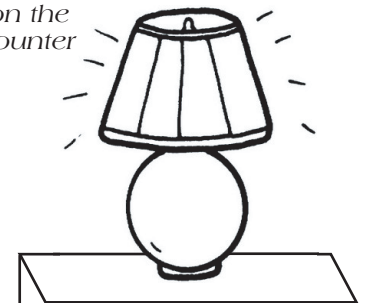



THE PUPPETS:

The puppets used in shadow theater were often jointed, with movable arms and legs. These will be solid figures, however once you get used to these, you may want to try looking into creating puppets with movable parts!

- Supplies: - card stock - wooden skewers
 - scissors - scotch tape - double-sided sticky tape

Print off the following pages of figures onto cardstock. Cut out around the outer edge of each figure, keeping as much of the detail as possible. Tape the figure to the skewer.

Cut out the two halves of the barn for use in the box. When the time comes for the stable scene, place one half against one side of the muslin frame and the other half on the other side. You can adhere them with double-sided sticky tape.

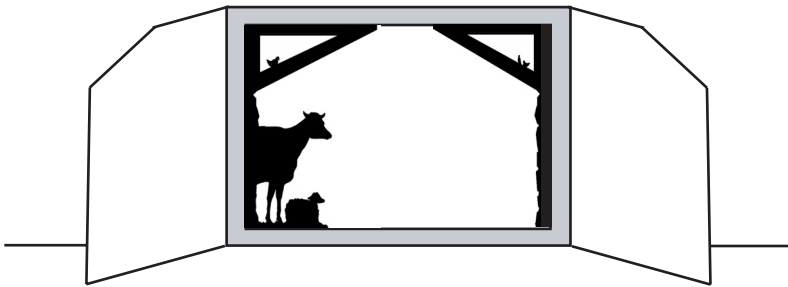

Depending on the size of your box, you may need to extend the rock wall sides of the stable. We have provided "extra rock wall" which you may want to add on to your stable walls. Don't be afraid to cut the pieces up! You only need to be concerned as to how the whole silhouette works. Feel free to tape together pieces, as well as remove pieces you would rather have separate. (For example, you may wish to remove the cow and sheep to allow more room for the Magi. If that is the case, you can make them an additional add-on.)

With your figures ready to go, sit behind the screen on the floor or a stool. You may want a table cloth on the table to hide you behind the stage! Keep the lamp a few feet from the back to have a general light. Turn out any unnecessary lighting in the room to make the picture clearer. Have someone narrate from a Nativity book, or read directly from the Bible using the book of Matthew, chapters 1 and 2. You can also add music and sound effects!



What a wonderful way to share the message of the birth of Jesus! Perform it for neighbors, friends, family, or at your Christmas gathering!

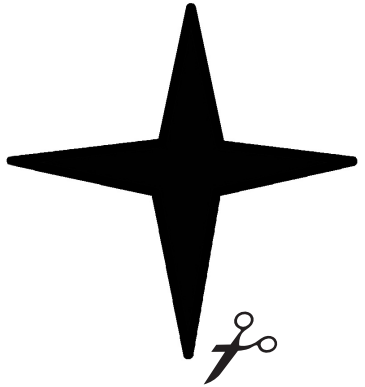
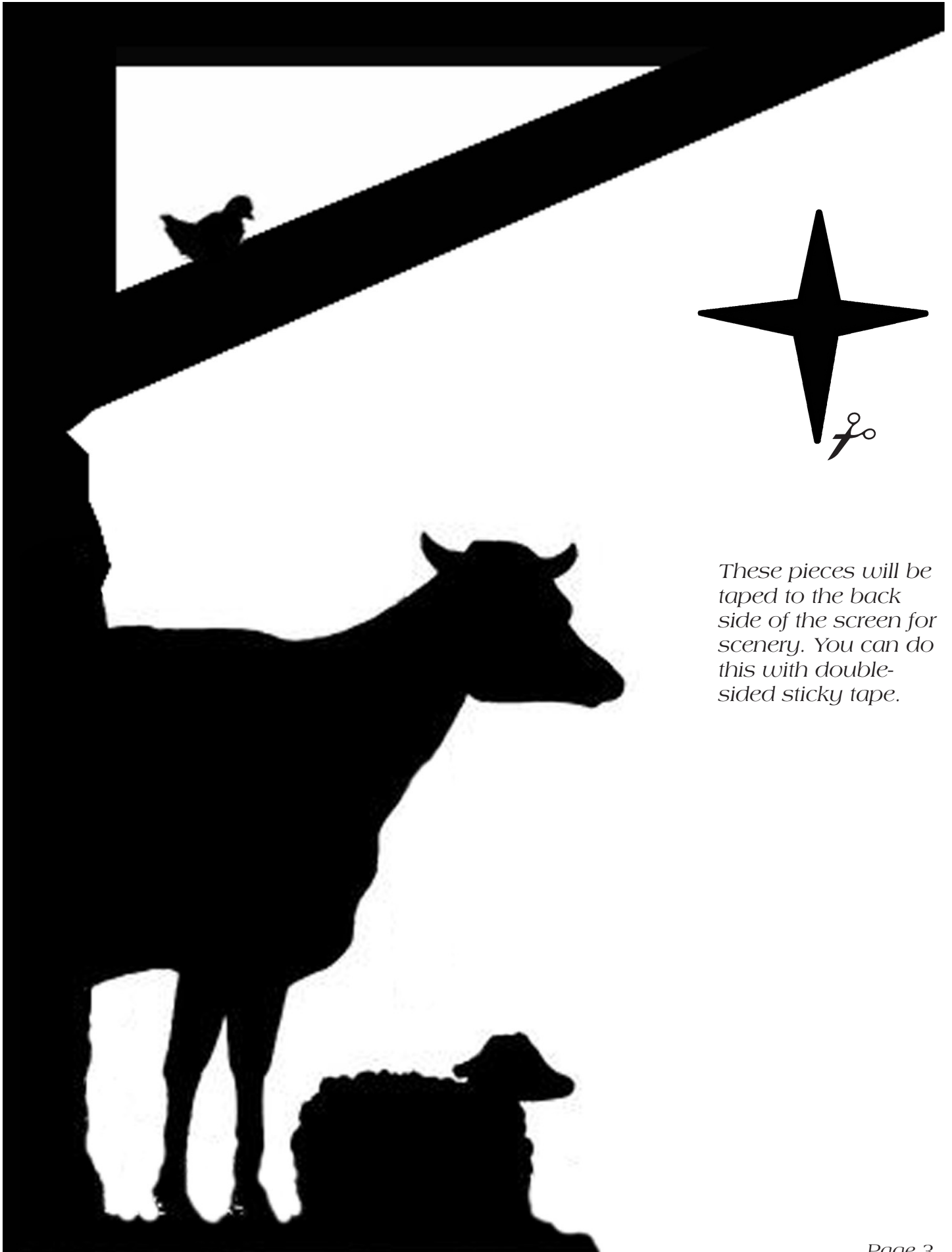

These pieces will be taped to the back side of the screen for scenery. You can do this with double-sided sticky tape.

*Opposite side of the
Stable. You can also use
this side for the Inn.*

Joseph & Mary



Jesus in the manger



These are the extra rocks for the stable walls, should you need to extend them.



You can use the dove to represent Jesus as the "Prince of Peace"



*Wisemen traveling
(include star from page 3)*

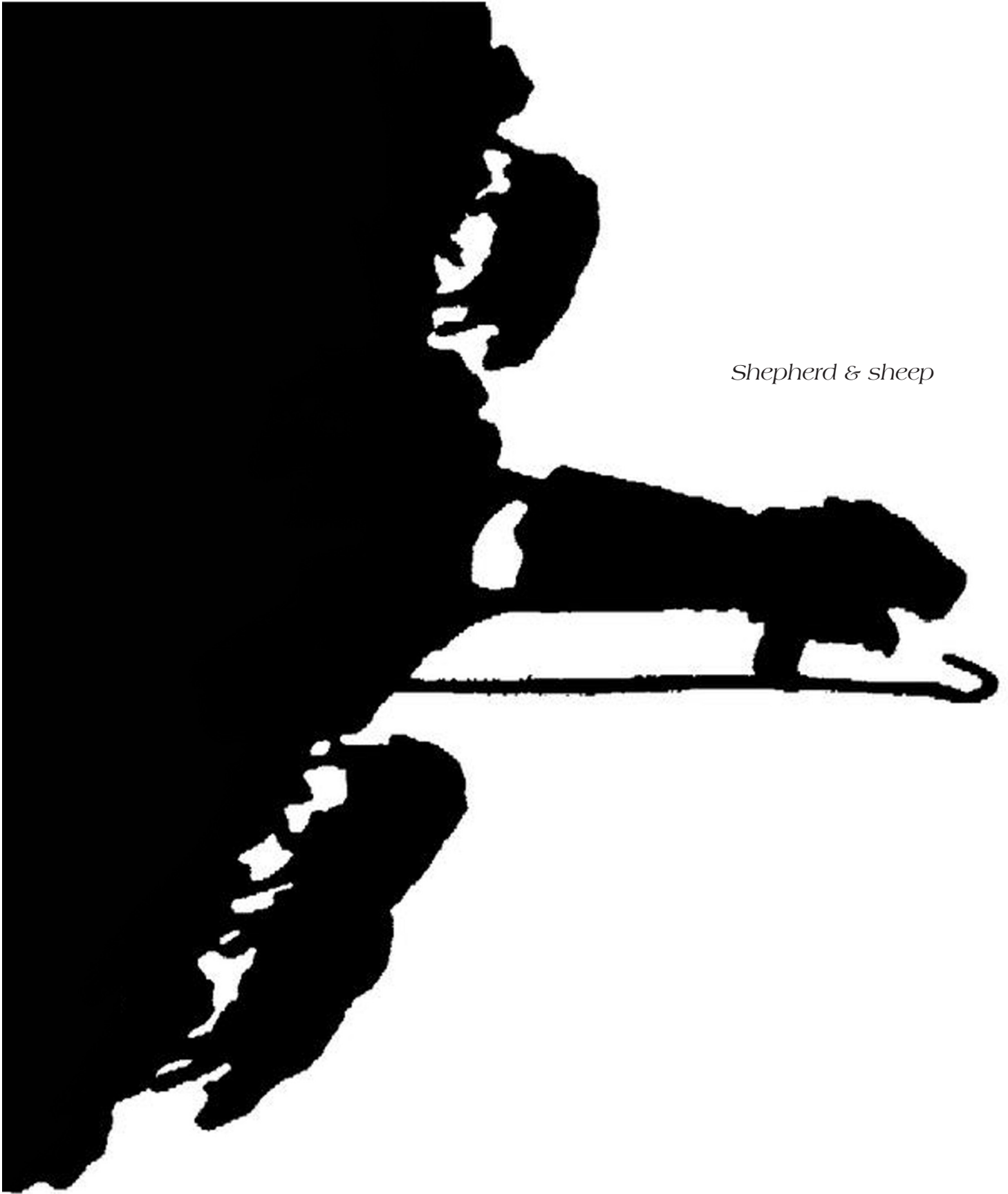

Shepherd & sheep



*Mary & Joseph
traveling to Bethlehem*

Three Kings presenting gifts



Inn Keeper



*Angel
(speaks to the shepherds)*

